



FLUORESCENT

TAMLITE LIGHTING

660 NW Peacock Blvd. Port St. Lucie, FL 34986
tel: (772) 878-4944 or on the web at www.tamliteusa.com

SPECIFICATION & FEATURES

Catalog Number
Notes
Job/Title

APPLICATIONS:

The 2X2 Cloud Series (CL) is a soft profile luminaire that provides an efficient light source for both residential and commercial environments. The shallow contemporary opal acrylic diffuser softly and evenly distributes light at comfortable levels.

CONSTRUCTION:

Cold-rolled steel body making for exceptional strength, durability, uniformity and dimensional stability.

FINISH:

Powder coated baked enamel finish provides safe handling and corrosion protection.

ELECTRICAL:

CONSULT FACTORY FOR BALLAST INFORMATION

WARRANTY:

Guaranteed one year from the purchase date of the product, against mechanical defects in manufacturing.

*** SPECIFICATIONS SUBJECT TO CHANGE WITHOUT NOTICE***

ORDERING INFORMATION

CL

Sample Part Code: CL2217A

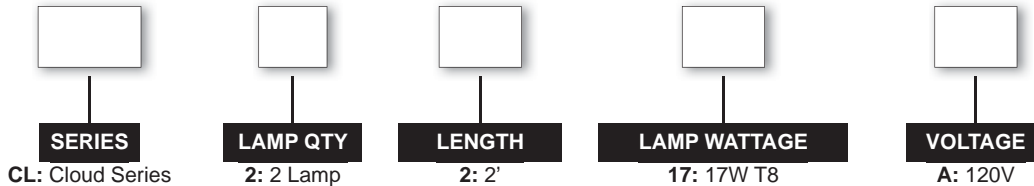

LAMP CONFIGURATION

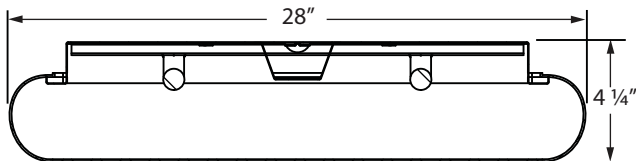

CL

2 X 2 Cloud Series

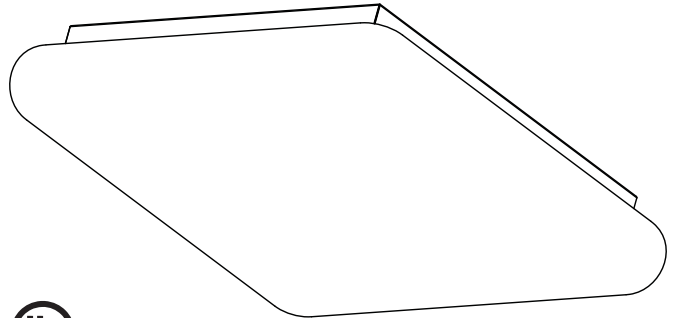

SPECIFICATIONS

LENGTH:	28"
WIDTH:	28"
DEPTH:	2 1/8" (metal) 4 1/4" (cloud)

MOUNTING INFORMATION

