



TAMLITE LIGHTING

660 NW Peacock Blvd. Port St. Lucie, FL 34986
tel: (772) 878-4944 or on the web at www.tamliteusa.com



SPECIFICATION & FEATURES

Catalog Number
Notes
Job/Title

DESCRIPTION:

BL4RAT is a 4" aperture remodel housing for one vertical Incandescent lamp UL, C-UL listed for damp location. The BL4RAT is thermally protected against misuse of insulation materials and improper lamping. This air-tight housing design prevents airflow through ceiling for saving heating and air conditioning costs. The BL4RAT offers a choice of trim types including baffle, reflector, lensed and eyeball trims.

HOUSING/MOUNTING FRAME:

The BL4RAT housing for remodel application where back side of ceiling is not accessible Installs through an opening in the ceiling from below. Secured in place by factory installed remodel springs. Design for use in non-insulated areas. If installed where insulation is present, the insulation must be pulled back 3" from all sides of the BL4RAT housing.

LAMPING/SOCKET:

50W Max., 120V (Lamp wattage based on trim). Adjustable socket mounting plate for proper positioning of different lamp types.

JUNCTION BOX:

J-box is listed for through-branch circuit wiring (5)11/16" knockouts, and (4) knockouts with Romex cable lamp. Ground wire is provided.

COMPLIANCE:

UL, C-UL listed for damp location.
Certified Air-Tight under ATM-E283

WARRANTY:

Guaranteed one year from the purchase date of the product, against mechanical defects in manufacturing.

*** SPECIFICATIONS SUBJECT TO CHANGE WITHOUT NOTICE***

BL4RAT

4" NON-IC Type Housing for Remodel Line Voltage



SPECIFICATIONS

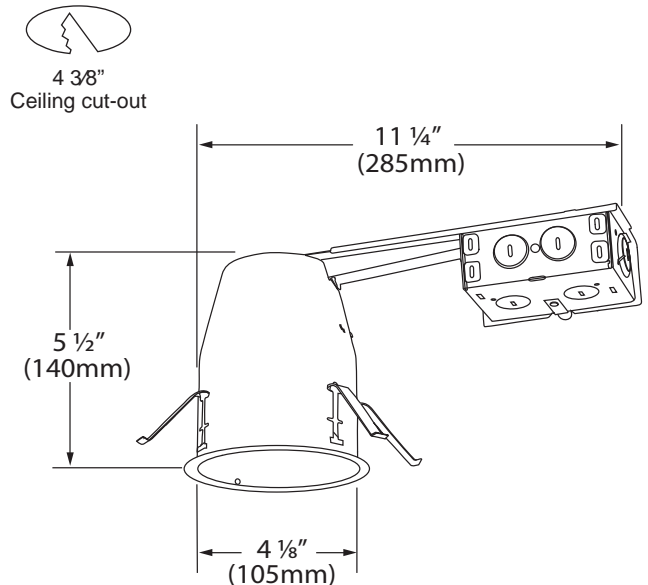

ORDERING INFORMATION

BL4RAT

Sample Part Code: BL4RAT

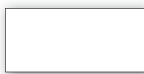

SERIES

BL4RAT: NON-IC Rated, Air Tight Remodel Housing