



TAMLITE LIGHTING

660 NW Peacock Blvd. Port St. Lucie, FL 34986
tel: (772) 878-4944 or on the web at www.tamliteusa.com



SPECIFICATION & FEATURES

Catalog Number
Notes
Job/Title

DESCRIPTION:

DLH104RE is a 4" aperture remodel housing for one vertical MR-16 halogen lamp UL, C-UL listed for damp location. The DLH104RE is thermally protected against misuse of insulation materials and improper lamping. The DLH104RE is designed for use in non-insulated areas. If installed where insulation is present, the insulation must be pulled back 3" from all sides of the housing. The DLH104RE offers a choice of trim types including baffle, reflector, lensed, and eyeball trims.

HOUSING/MOUNTING FRAME:

The DLH104RE housing for remodel application where back side of ceiling is not accessible. Installs through an opening in the ceiling from below. Secured in place by factory installed remodel springs. 5 1/2" height allows to use in 2" x 6" joist construction.

LAMPING/SOCKET:

50W Max., 12V GU5.3 base MR-16 (Lamp wattage based on trim). Adjustable socket mounting plate for proper positioning of different lamp types. Uses 120V to 12V electronic transformer.

JUNCTION BOX:

J-box is listed for through-branch circuit wiring (5) 11/16" knockouts, and (4) knockouts with Romex cable lamp. Ground wire is provided.

COMPLIANCE:

UL, C-UL listed for damp location.

WARRANTY:

Guaranteed one year from the purchase date of the product, against mechanical defects in manufacturing.

*** SPECIFICATIONS SUBJECT TO CHANGE WITHOUT NOTICE***

DLH104RE

4" NON-IC Type Housing for Remodel Low Voltage



DIMENSIONS DATA

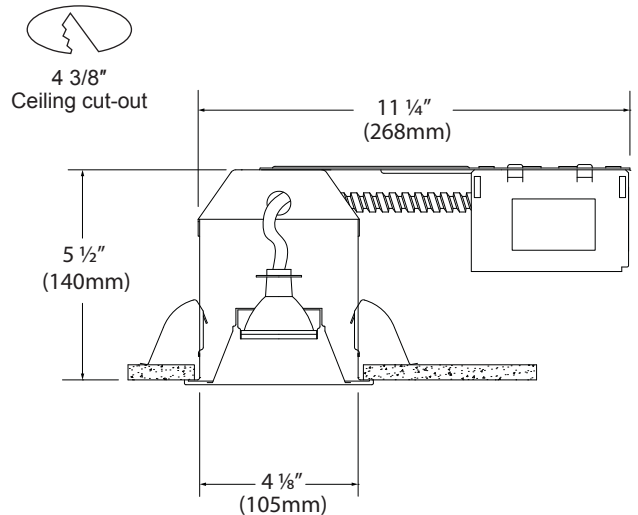

ORDERING INFORMATION

DLH104RE

Sample Part Code: DLH104RE

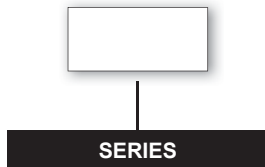

DLH104RE: NON-IC Rated, Electronic Transformer, Remodel Housing