



TAMLITE LIGHTING

660 NW Peacock Blvd. Port St. Lucie, FL 34986
tel: (772) 878-4944 or on the web at www.tamliteusa.com

SPECIFICATION & FEATURES

Catalog Number
Notes
Job/Title

ESR-16WP Series

Thermoplastic Emergency Light

Wet Locations



DESCRIPTION:

The ESR-16WP Series thermoplastic adjustable emergency lighting for wet locations offer long lamp life, energy efficiency and uniform illumination in an economical package.

CONSTRUCTION:

The ESR-16WP is constructed of molded fiberglass. A fully gasketed clear polycarbonate cover encloses lamps and reflectors, and offers protection against wet, non-hazardous dust, and hose down locations.

ILLUMINATION:

Supplied with 6V, 7W MR16 halogen bi-pin lamps.

ELECTRICAL:

Dual 120V/277V voltage Rated for use in damp locations has AC power indicator and LVD (low voltage disconnect) prevents battery from deep discharge. Fully automatic solid-state, two-rate charger initiates battery charging to recharge a discharged battery in 24 hours. Internal solid-state transfer switch automatically connects the internal battery to LED board for minimum 90-minute emergency illumination. 6V 4.5Ah, sealed lead acid, maintenance-free, rechargeable battery. (EM model).

OPTIONS:

HTR: Internal Heater enables the unit to be used in cold environments.

CODE COMPLIANCE:

UL listed for wet locations & meets UL924, NFPA 101 Life Safety Code compliant, NEC and OSHA compliant.

MOUNTING:

Suitable for wall or ceiling mounting – Mounting plate includes universal mounting pattern for simple mounting over J-box.

WARRANTY:

Guaranteed for five year against mechanical defects in manufacturing. Batteries are pro-rated warranted for 5 years.

*** SPECIFICATIONS SUBJECT TO CHANGE WITHOUT NOTICE***

DIMENSIONS DATA

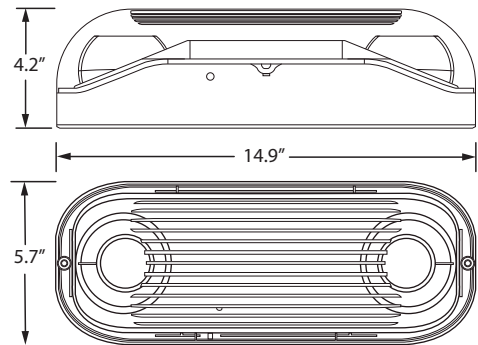

ORDERING INFORMATION

ESR-16WP

Sample Part Code: ESR-16WPEM

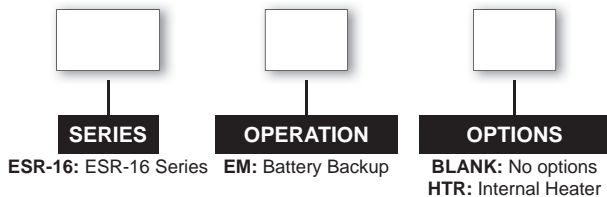



SPECIFICATION & FEATURES

ESR-16WP

Thermoplastic Emergency Light Wet Locations

PHOTOMETRIC DATA

6V, 5.4W Tungsten Wedge Base Lamp (ANSI 939), Square Head (Replacement Lamp ESLMP-6V5)

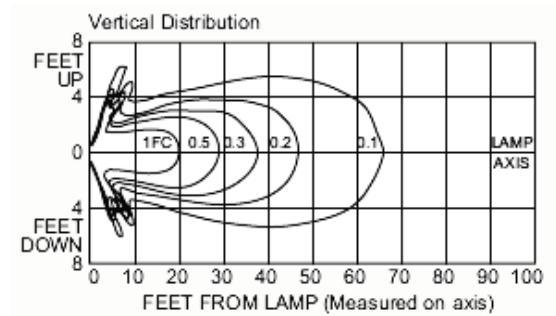
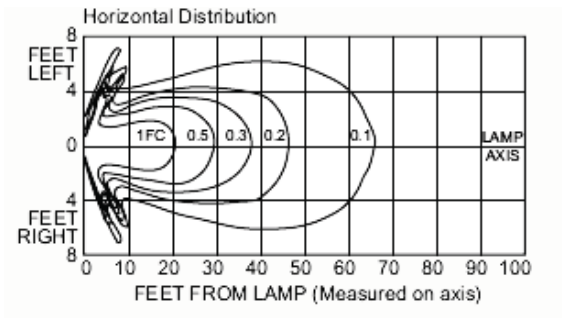

BATTERY DATA

Lead Calcium battery are warranted for one full year with additional 4 years pro-rated warranty
Recharges in 24 hours or less (Replacement battery BL930007)

Type	Battery Voltage	Shelf Life ¹	Expected Life ¹	Temperature Range ²
SLA - Sealed Lead Acid	6V, 4.5Ah	15 months	5-8 years	40°F-95°F
¹ At 77°F				
² To obtain rated life and capacity.				

Application and Performance Specification Information is Subject to Change Without Notification