



TAMLITE LIGHTING

660 NW Peacock Blvd. Port St. Lucie, FL 34986
tel: (772) 878-4944 or on the web at www.tamliteusa.com

SPECIFICATION & FEATURES

Catalog Number
Notes
Job/Title

ESTFX-2 Series Waterproof Emergency Light



DESCRIPTION:

The ESTFX-2 Series Wet Location Emergency Lights feature construction that is ideal for wet locations, while also being resistant to corrosive atmospheres, non-hazardous dust environments, frequent hose-downs, water spray or splashing water.

CONSTRUCTION:

The ESTFX-2 has a corrosion and impact-resistant polycarbonate housing in industrial gray finish. The housing is sealed and gasketed with a hinged cover, sealed test switch and power indicator light. Incorporates an integral breather vent and external mounting brackets for simplified wall mounting. Has sealed and gasketed weatherproof lighting heads with tempered glass lenses. Listed for wet location applications.

HEADS:

Includes two 6V, 7.2W lighting heads with tempered glass lenses for additional durability and are sealed and gasketed.

ELECTRICAL:

Dual 120V/277V voltage, Rated for use in wet locations has AC power indicator and LVD (low voltage disconnect) prevents battery from deep discharge. Fully automatic solid-state, two-rate charger initiates battery charging to recharge a discharged battery in 24 hours. Internal solid-state transfer switch automatically connects the internal battery to lamps for minimum 90-minute emergency illumination. Long-life, maintenance-free, rechargeable 6V sealed lead acid battery.

OPTIONS:

SD: Self-Diagnostic continually diagnoses unit's performance and tests system (auto battery discharge once every 30 days and once every 12 months) to ensure reliable operation and to meet electrical and life safety codes.

RC: Dual maintenance-free, 6-volt premium grade, pure lead acid battery. The RC version will operate the sign and two 7.2W heads plus an additional 15W remote load for a minimum of 90 minutes.

CODE COMPLIANCE:

UL listed for wet locations (0°C-40°C) & meets UL924, NFPA 101 Life Safety Code compliant, NEC and OSHA compliant.

MOUNTING:

External mounting brackets for simplified wall mounting.

WARRANTY:

Guaranteed for one year against mechanical defects in manufacturing.

*** SPECIFICATIONS SUBJECT TO CHANGE WITHOUT NOTICE***

DIMENSIONS DATA

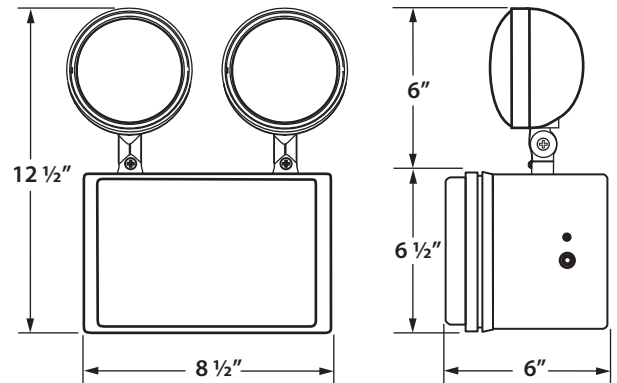

ORDERING INFORMATION

ESTFX-2

Sample Part Code: ESTFX-2

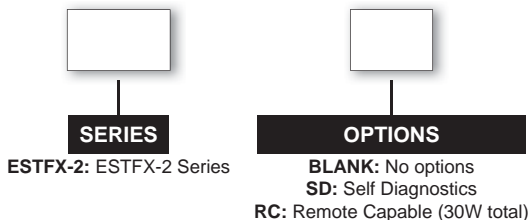



SPECIFICATION & FEATURES

ESTFX-2 Series

Waterproof Emergency Light

PHOTOMETRIC DATA

6V, 7.2W Tungsten Wedge Base Lamp (ANSI 927), Round Head

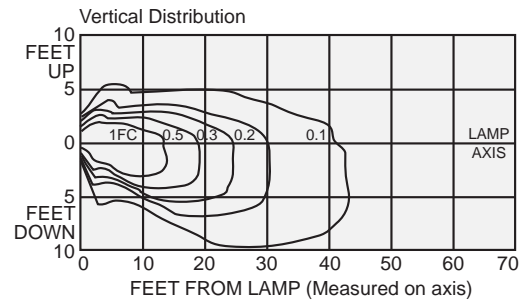
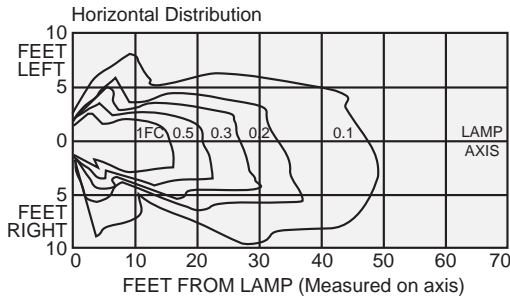

BATTERY DATA

Lead Calcium battery are warranted for one full year with additional 4 years pro-rated warranty
Recharges in 24 hours or less

Type	Battery Voltage	Shelf Life ¹	Expected Life ¹	Temperature Range ²
SLA - Sealed Lead Acid	Two 6V, 7.2Ah	15 months	5-8 years	40°F-95°F
SLA - Sealed Lead Acid (RC)	Four 6V, 7.2Ah	15 months	5-8 years	40°F-95°F

¹ At 77°F
² To obtain rated life and capacity.

ENGINEERING DATA

	INPUT VOLTAGE	MAX. AMPS	MAX. WATTS
ESTFX-2	120	0.59	6.1
ESTFX-2	277	0.28	6.4

* Fully charged battery.

Application and Performance Specification Information is Subject to Change Without Notification