



TAMLITE LIGHTING

660 NW Peacock Blvd. Port St. Lucie, FL 34986
tel: (772) 878-4944 or on the web at www.tamliteusa.com



SPECIFICATION & FEATURES

CONSTRUCTION:

The heads and body of the MS series are constructed of corrosion resistant polycarbonate and pre-wired/pre-assembled for easy field installation.

ADJUSTABILITY:

Both heads feature "No Tool Adjustments" at the base and knuckle allowing for a simple set up or change of the each head's direction.

SENSOR:

The MS series features power-on test mode, manual override, sensitivity and time adjustment. Offers tool-less sensor adjustments. Fixture works on the principles of passive infrared sensing ambient temperature will effect performance.

ELECTRICAL:

2 - 150W PAR38 max. (lamps sold separately) 120VAC - 60Hz

MOUNTING:

Can be mounted under eaves or wall. Mounting hardware is included.

LISTING & RATINGS:

UL listed for Wet Location.

WARRANTY:

Guaranteed for one year against mechanical defects in manufacturing.

*** SPECIFICATIONS SUBJECT TO CHANGE WITHOUT NOTICE***

SENSOR DETECTION DATA

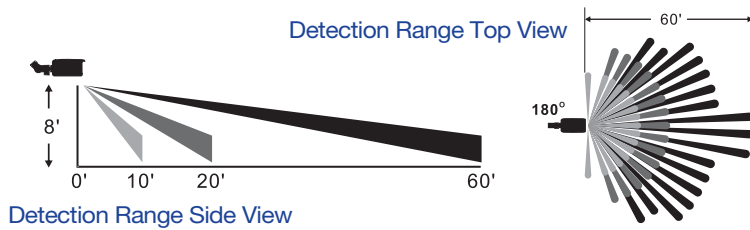

ORDERING INFORMATION

MSP2180

Sample Part Code: MSP2180WH



SERIES

MSP2180: MSP2180 Series



HOUSING COLOR

WH: White
BZ: Bronze

Catalog Number
Notes
Job/Title

MS Series FLOODLIGHT W/180° SENSOR



DIMENSIONS DATA

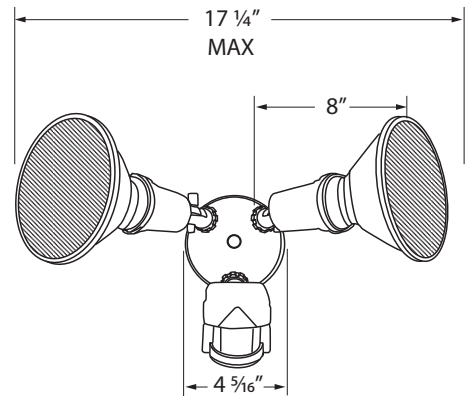

ACCESSORIES/REPLACEMENT ITEMS

PART CODE	DESCRIPTION
MS180BZ	180° MOTION SENSOR ONLY BRONZE
MS180WH	180° MOTION SENSOR ONLY WHITE
MSHBZ	PAR 38 LAMP HOLDER HOOD BRONZE
MSHWH	PAR 38 LAMP HOLDER HOOD WHITE
MSP2BZ	PAR 38 LAMP HOLDER 2 HEAD BRONZE
MSP2WH	PAR 38 LAMP HOLDER 2 HEAD WHITE