



TAMLITE LIGHTING

660 NW Peacock Blvd. Port St. Lucie, FL 34986
tel: (772) 878-4944 or on the web at www.tamliteusa.com

SPECIFICATION & FEATURES

HOUSING:

Extruded aluminum housing, die-cast aluminum ballast housing, choice of white, black, or bronze powder coat finish over a chromate conversion coating, hinged ballast compartment for easy wiring access.

REFLECTOR:

Internal aluminum reflectors

LENS:

Clear tempered glass lens

SOCKET:

HID: Porcelain 4KV pulse rated medium base socket with nickel-plated screw shell.
PL: Plug-in type, GX24Q-4.

MOUNTING:

Mount over a 4" recessed outlet box. Includes Easy-Hang "Two Hands Free" wall mounting bracket

ELECTRICAL:

High Pressure Sodium: 35W to 150W
Metal Halide: 50W to 150W
Compact Fluorescent: 52W to 84W
(2x26, 2x32, 2x42)
120-277V electronic ballast

LISTING & RATINGS:

CSA: Listed for wet locations.

WARRANTY:

Guaranteed for one year against mechanical defects in manufacturing

*** SPECIFICATIONS SUBJECT TO CHANGE WITHOUT NOTICE***

Catalog Number
Notes
Job/Title

WCU

Wall Cylinder Up/Down Light

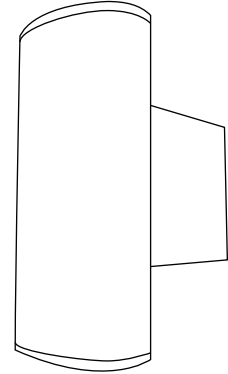

DIMENSIONS DATA

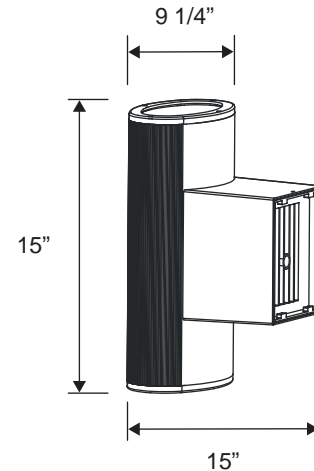

Max. Weight: 22 LBS.

ORDERING INFORMATION

CATALOG#	DESCRIPTION	VOLTAGE	BALLAST
FLUORESCENT¹			
WCU2X26DL ¹	52 WATT PL	120-277	ELECTRONIC
WCU2X32DL ¹	64 WATT PL	120-277	ELECTRONIC
WCU2X42DL ¹	84 WATT PL	120-277	ELECTRONIC
¹ Battery back-up available by adding "B1" to end of part code for 120V or "B2" for 277V.			
HIGH PRESSURE SODIUM			
WCUHPA35L	35 WATT HPS	120	R-NPF
WCUHPA50L	50 WATT HPS	120	R-NPF
WCUHPA70L	70 WATT HPS	120	R-NPF
WCUHPA100L	100 WATT HPS	120	R-NPF
WCUHPA150L	150 WATT HPS	120	R-NPF
WCUHPQ70L	70 WATT HPS	QUAD TAP	HX-HPF
WCUHPQ100L	100 WATT HPS	QUAD TAP	HX-HPF
WCUHPQ150L	150 WATT HPS	QUAD TAP	HX-HPF
METAL HALIDE			
WCUMHQ50L	50 WATT MH	QUAD TAP	HX-HPF
WCUMHQ70L	70 WATT MH	QUAD TAP	HX-HPF
WCUMHQ100L	100 WATT MH	QUAD TAP	HX-HPF
WCUMHQ150L	150 WATT MH	QUAD TAP	HX-HPF
Lamp included			